

### Specifications

MODEL	GRC™-12	
Measurements	Metric	US
Working height*	5.66 m	18 ft
Platform height	3.66 m	12 ft
<b>A</b> <b>B</b> Platform dimensions (length x width)		
Ext Platform dimensions - retracted	99 x 75 cm	39 x 29.5 in
Ext Platform dimensions - extended	1.4 m x 75 cm	55 x 29.5 in
<b>C</b> Height - stowed	1.70 m	67 in
<b>D</b> Length - stowed	1.37 m	4 ft 6 in
<b>E</b> Width	80 cm	2 ft 7.5 in
<b>F</b> Ground clearance - center	6.3 cm	2.5 in

### Productivity

Max platform occupancy (indoor/outdoor) <sup>1</sup>	2/-	2/-
Lift capacity	227 kg	500 lbs
Drive speed - stowed	4.0 km/h	2.5 mph
Drive speed - raised	0.8 km/h	0.5 mph
Gradeability**	30%	30%
Turning radius - inside	zero	zero
Turning radius - outside	1.35 m	4 ft 5 in
Raise / lower speed	12 / 16 sec	12 / 16 sec
Controls	24V DC proportional	24V DC proportional
Tyres - solid non-marking	25 x 8 x 20 cm	10 x 3 x 8 in

### Power

Power source	24V (four 6V 225 Ah batteries)	
Hydraulic system capacity	8.33 L	2.2 gal

### Sound & Vibration Levels

Sound pressure level (ground workstation)	<70 dBA
Sound pressure level (platform workstation)	<70 dBA
Vibration	<2.5 m/s <sup>2</sup> <98.4 in/s <sup>2</sup>

### Weight\*\*\*

	950 kg	2,094 lbs
--	--------	-----------

### Standards Compliance

ANSI A92.6, CSA B354.2, CE Compliance, AS 1418.10

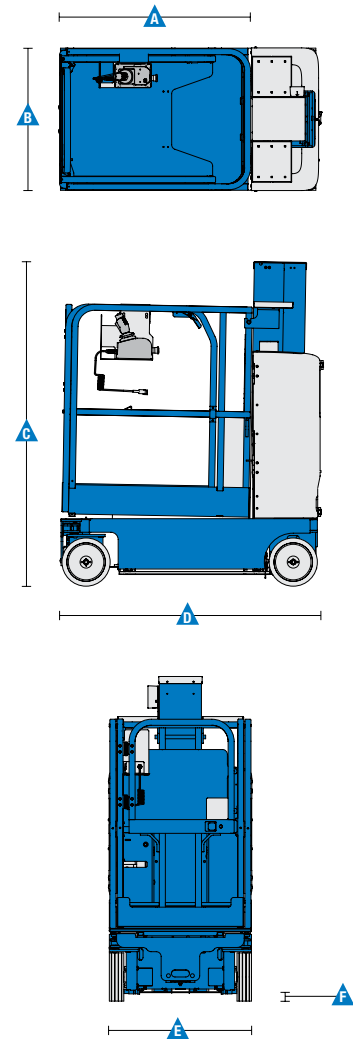

<sup>1</sup> Indoor use only.

\* The metric equivalent of working height adds 2 m to platform height. U.S. adds 6 ft to platform height.

\*\* Gradeability applies to driving on slopes. See operator's manual for details regarding slope rating.

\*\*\* Weight will vary depending on options and/or country standards.

### Features

#### Standard Features

##### Measurements

- 5.66 m (18 ft) working height
- 3.66 m (12 ft) platform height
- Up to 227 kg (500 lbs) lift capacity

##### Productivity

- 2-person rated
- Smart Link™ control system (joystick, 2 proportional lift speeds & 2 selectable proportional drive speeds, user-friendly diagnostics)
- Auxiliary platform lowering
- Low 39 cm (15.5 in) platform entry height
- Work station tray
- Steel tube-in-tube mast system
- Compact base 80 cm x 1.37 m (31.5 x 54 in)
- Ground clearance 6.4 cm (2.5 in) (stowed)
- Fully proportional lift and drive controls
- Battery charge indicator
- On-board diagnostic system
- Descent and tilt alarm
- Zero inside turning radius
- Dual wheel brakes
- Hydraulic brake release
- Pothole protection
- Hinged rear ABS covers for easy access to all major electrical and hydraulic components
- Tie down attachment points
- Overhead crane attachment point
- Large forklift pockets access
- Certified load sensor
- Dual flashing beacons
- Motion alarm
- Automotive-style horn
- Drive cutout while charging

#### Standard Features

##### Platform

- 99 cm x 75 cm (39 x 29.5 in) steel platform and extension deck with swing gate

##### Power

- 24V (four 6V 225 Ah batteries) with automatic 25 amp battery charger

##### Tyres

- Non-marking solid

#### Options & Accessories

##### Productivity Options

- 240 V power to platform
- Biodegradable hydraulic oil

##### Power Options

- AGM maintenance-free batteries



Genie – Toll free number 1800 788 633

#### Brisbane

HEAD OFFICE  
33 Kimberley Street  
Darra QLD 4076

#### Sydney

74 Glendenning Road  
Glendenning NSW 2761

#### Melbourne

374 Hammond Road  
Dandenong VIC 3175

#### Adelaide

16-18 Nixon Road  
Wingfield SA 5013

#### Perth

126 Sheffield Road  
Welshpool WA 6106

#### Darwin

33 McCourt Road  
Yarrawonga NT 0830

#### Genie USA

18340 NE 76th Street  
P.O. Box 97030  
Redmond, Washington  
98073-9730

#### Distributed By:

Effective Date: July, 2015. Product specifications and prices are subject to change without notice or obligation. The photographs and/or drawings in this document are for illustrative purposes only. Refer to the appropriate Operator's Manual for instructions on the proper use of this equipment. Failure to follow the appropriate Operator's Manual when using our equipment or to otherwise act irresponsibly may result in serious injury or death. The only warranty applicable to our equipment is the standard written warranty applicable to the particular product and sale and we make no other warranty, express or implied. Products and services listed may be trademarks, service marks or trade names of Terex Corporation and/or their subsidiaries in the USA and many other countries. Genie is a registered trademark of Terex South Dakota, Inc. © 2015 Terex Corporation.